

## 6 H 1,5 CP 16Ω

Studio Monitor

6" | 240 W

Code Z004038

- 1,5" voice coil Kapton former
- PS Spider with Progressive Waves
- DAR Rubber surround with Double Asymmetric Rolls Technology (DAR)
- DT Damping Cone Treatment
- Ferrite Magnet Circuit
- VM Ventilated Magnet to reduce Power Compression
- 89.7 dB sensitivity
- Frequency Range 45-4500 Hz

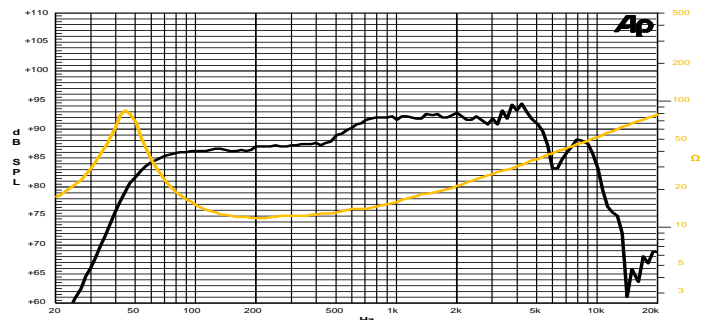
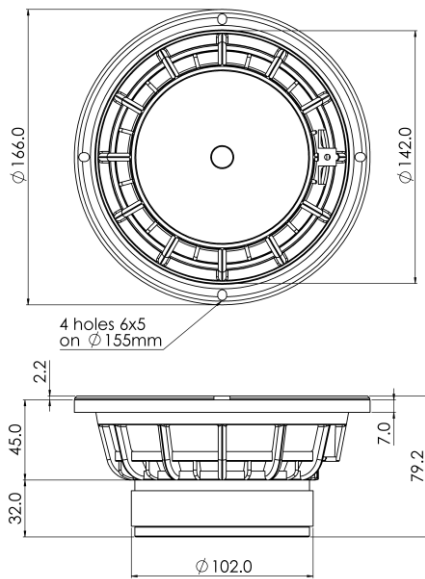

Frequency Response on 18 Lt @ 50 Hz Vented Box @ 1W, 1m  
Free Air Impedance

### General Specifications

Nominal Diameter	166 mm (6")
Nominal Impedance	16 $\Omega$
Rated Power AES <sup>(1)</sup>	120 W
Continuous Program Power <sup>(2)</sup>	240 W
Sensitivity @ 1W/1m <sup>(3)</sup>	89.7 dB
Voice Coil Diameter	38 mm (1,5")
Voice Coil Winding Depth	14 mm
Magnetic Gap Depth	6 mm
Flux Density	1.03 T
Magnet Weight	515 g
Net Weight	1.6 kg

### Thiele & Small Parameters <sup>(4)</sup>

$R_e$	10.40 $\Omega$	$F_s$	45.0 Hz
$Q_{ms}$	3.95	$Q_{es}$	0.42
$Q_{ts}$	0.38	$M_{ms}$	15.2 g
$C_{ms}$	823 $\mu$ m/N	$B_{xl}$	10.30 Tm
$V_{as}$	17.6 l	$S_d$	122.7 cm <sup>2</sup>
$X_{max}^{(5)}$	+/-6.0 mm	$X_{var}^{(6)}$	+/-9.0 mm
$\eta_0$	0.37 %	$L_e$ (1kHz)	1.13 mH

### Constructive Characteristics

Magnet	Ferrite
Basket Material	Aluminium Die-Cast
Voice Coil Winding Material	Copper
Voice Coil Former Material	Kapton
Cone Material	Paper
Cone Treatment	Surface Damping Treatment
Surround Material	Rubber
Dust Dome Material	Solid Paper

### Mounting Information

Overall Diameter	166 mm
Baffle Cutout Diameter	143 mm
Mounting Holes	4 holes 5x6 on $\varnothing$ 155 mm
Total Depth	mm

(1) Rated Power measured with 2-hour test with pink noise signal, 6dB crest factor, loudspeaker in free air, power calculated on rated Zmin. (2) Power on Continuous Program is defined as 3dB greater than the Rated Power. (3) Calculated by Thiele & Small parameters, for SPL average in box refer to frequency response. (4) Thiele & Small parameters measured with laser system after preconditioning test. (5) Measured with respect to a THD of 10%. (6) Value corresponding to a decay of the Force Factor, or Compliance, or both, equal to the 50% of the small signal value. (7) Drawing dimensions: mm.