

12 SR 4 CP 8Ω

12" | 2000 W

Code Z007956

Subwoofer

- SNDW** 4" Sandwich voice coil Fiberglass former
- DCS** Double Cross Konex Spider (DCS)
- DAR** Rubber surround with Double Asymmetric Rolls Technology (DAR)
- TWPt** Waterproof Cone Treatment
- HeF** High Excursion Ferrite Magnet Circuit
- VMVc** Ventilated Magnet and Voice Coil to reduce Power Compression
- 92.6 dB sensitivity
- Frequency Range 35-2000 Hz

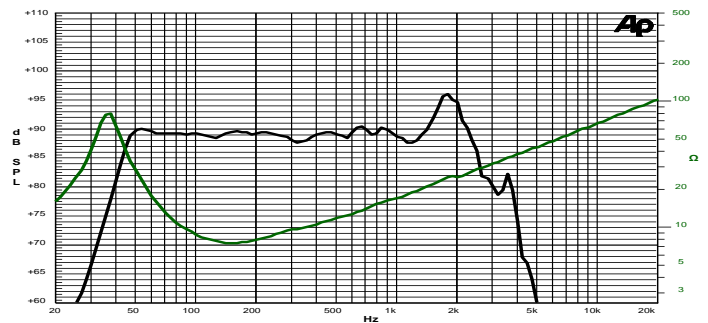
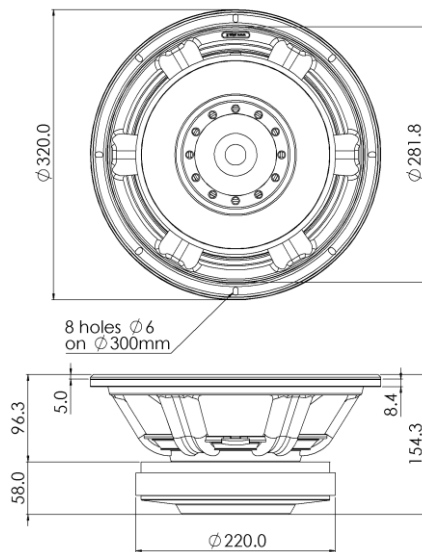

Frequency Response on 60 Lt @ 45 Hz Vented Box @ 1W, 1m
Free Air Impedance

General Specifications

Nominal Diameter	321 mm (12")
Nominal Impedance	8 Ω
Rated Power AES ⁽¹⁾	1000 W
Continuous Program Power ⁽²⁾	2000 W
Sensitivity @ 1W/1m ⁽³⁾	92.6 dB
Voice Coil Diameter	100 mm (4")
Voice Coil Winding Depth	27 mm
Magnetic Gap Depth	12 mm
Flux Density	1.12 T
Magnet Weight	3300 g
Net Weight	12.0 kg

Thiele & Small Parameters ⁽⁴⁾

Re	5.2 Ω	Fs	38.0 Hz
Qms	4.78	Qes	0.31
Qts	0.30	Mms	144.6 g
Cms	122 μm/N	Bxl	24.00 Tm
Vas	41.7 l	Sd	490.9 cm ²
X max ⁽⁵⁾	+/-9.0 mm	X var ⁽⁶⁾	+/-10.0 mm
η _o	0.71 %	Le (1kHz)	1.77 mH

Constructive Characteristics

Magnet	Ferrite
Basket Material	Aluminium Die-Cast
Voice Coil Winding Material	Copper
Voice Coil Former Material	Fiberglass
Cone Material	Paper
Cone Treatment	Surface Waterproof Treatment
Surround Material	Rubber
Dust Dome Material	Solid Paper

Mounting Information

Overall Diameter	320 mm
Baffle Cutout Diameter	284 mm
Mounting Holes	8 holes ø6 on ø300 mm
Total Depth	154.3 mm

⁽¹⁾ Rated Power measured with 2-hour test with pink noise signal, 6dB crest factor, loudspeaker in free air, power calculated on rated Zmin. ⁽²⁾ Power on Continuous Program is defined as 3dB greater than the Rated Power. ⁽³⁾ Calculated by Thiele & Small parameters, for SPL average in box refer to frequency response. ⁽⁴⁾ Thiele & Small parameters measured with laser system after preconditioning test. ⁽⁵⁾ Measured with respect to a THD of 10%. ⁽⁶⁾ Value corresponding to a decay of the Force Factor, or Compliance, or both, equal to the 50% of the small signal value. ⁽⁷⁾ Drawing dimensions: mm.