

MODULE SERIES

Active Speaker Module



Operation Manual

Important Safety Precautions & Explanation of Symbols



The lightning flash with arrowhead symbol within an equilateral triangle is intended to alert the user to the presence of uninsulated ? dangerous? voltage within the product's enclosure that may be of sufficient magnitude to constitute a risk of electric shock to humans.



The exclamation point within an equilateral triangle is intended to alert the user to the presence of important operating and maintenance (servicing) instructions in this manual.



The lightning flashes printed next to the output terminals of the amplifier are intended to alert the user to the risk of hazardous energy. Output connectors that could pose a risk are marked with the lightning flash. Do not touch output terminals while amplifier power is on. Make all connections with amplifier turned off.



CAUTION: TO REDUCE THE RISK OF ELECTRIC SHOCK, DO NOT REMOVE THE COVER. NO USER-SERVICEABLE PARTS INSIDE. REFER SERVICING TO QUALIFIED PERSON NEL.



WARNING: To prevent fire or electric shock, do not expose this equipment to rain or moisture.



Do not put any containers that hold water on the amplifier, just in case the water would drip into the amplifier and cause electric shock.



User is responsible to choose matched speaker for the amplifier so as to avoid damage to speaker. We are not responsible if the speaker was damaged. Please consult to speaker factory for details.

This amplifier has a serial number located on the rear panel. Please write this and the model number down and keep them for your records. Keep your purchase receipt. It is your proof of purchase.

Serial Number: _____

Date of Purchase: _____

Purchased From: _____

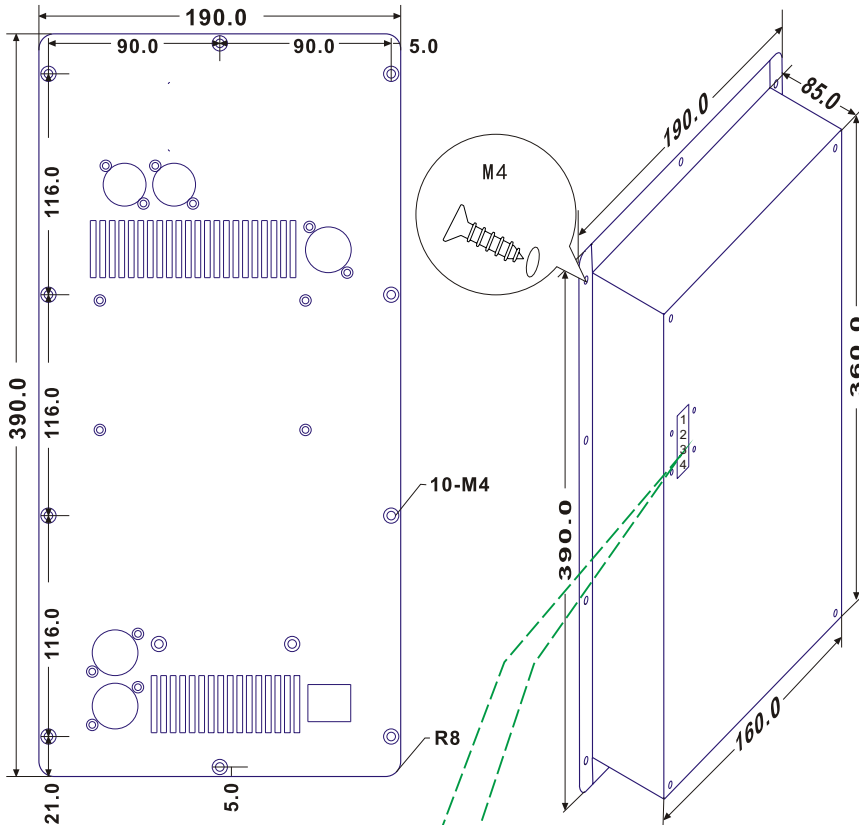

Installation dimension drawing (Unit: mm)

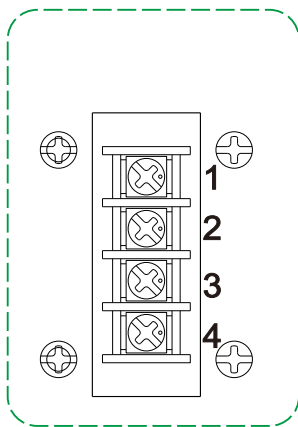

Application	1 input, 1 audio parallel output, mono module. Applied to linearray with crossover.		
Control	Amplifier can't be adjusted by panel, it needs a pre-stage to use with.		
Diagram			
Model	K9	K12	K15
8Ω output power	900W	1200W	1500W
4Ω output power	1440W	1920W	2400W

Connector	Input: XLR Output: SPEAKON or KF25C-7.62 barrier terminal		
Input sensitivity: 1.8V; Input impedance: 20KΩbalanced; Damping factor: > 400 @ 8Ω; Hum&noise: -95dB ; THD: < 0.1% (20Hz - 20KHz, 1W) Frequency response: 20Hz - 20KHz (±0.3dB) @ 1W,8Ω ; cooling: temperature controlled ; Protection: short circuit, open circuit, direct voltage, overheat, overvoltage, radio-frequency, ultralow frequency; power requirement: AC 180V-240V or AC90V-120V , 50-60Hz ; Module size: 390mm X 190mm X 88mm; Packing size: 385mm X 330mm X 160mm			
Net weight	5.6		
Gross weight	6.2		

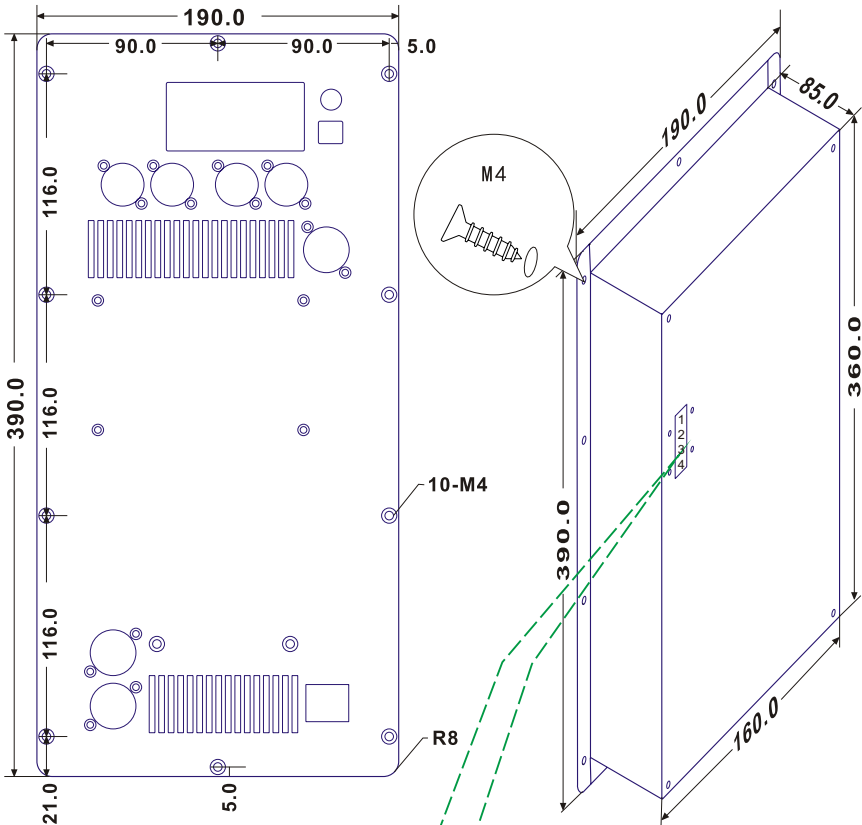

Installation dimension drawing (Unit: mm)

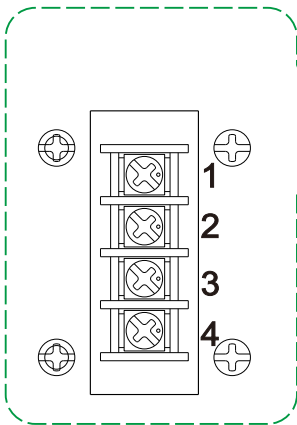

Application	2 inputs, 2 audio parallel outputs, DSP 4 channels module. Applied to full range speaker.		
Control	by encoder or by software. 1-A, 2-B, 3-C & 4-D are available.		
Diagram			
Model	M2.9	M2.12	M2.15
8Ω output power	2X900W	2X1200W	2X1500W
4Ω output power	2X1440W	2X1920W	2X2400W

Connector	Input: XLR Output: SPEAKON or KF25C-7.62 barrier terminal		
Input sensitivity: 1.8V; Input impedance: 20KΩbalanced; Damping factor: > 400 @ 8Ω; Hum&noise: -95dB ; THD: < 0.1% (20Hz - 20KHz, 1W) Frequency response: 20Hz - 20KHz (±0.3dB) @ 1W,8Ω ; cooling: temperature controlled ; Protection: short circuit, open circuit, direct voltage, overheat, overvoltage, radio-frequency, ultralow frequency; power requirement: AC 180V-240V or AC90V-120V , 50-60Hz ; Module size: 390mm X 190mm X 88mm; Packing size: 385mm X 330mm X 160mm			
Net weight	5.8KG		
Gross weight	6.4KG		

Active Speaker Module

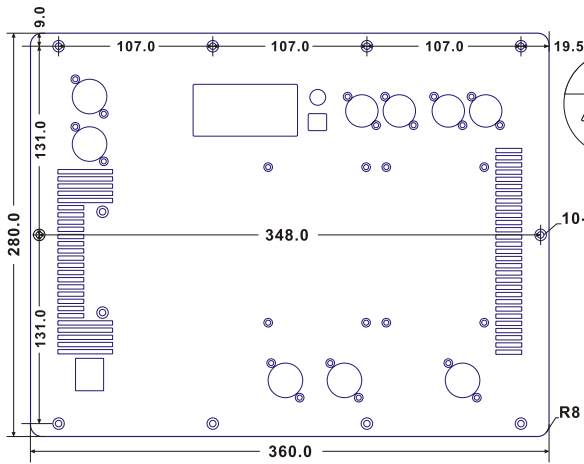

Installation dimension drawing (Unit: mm)

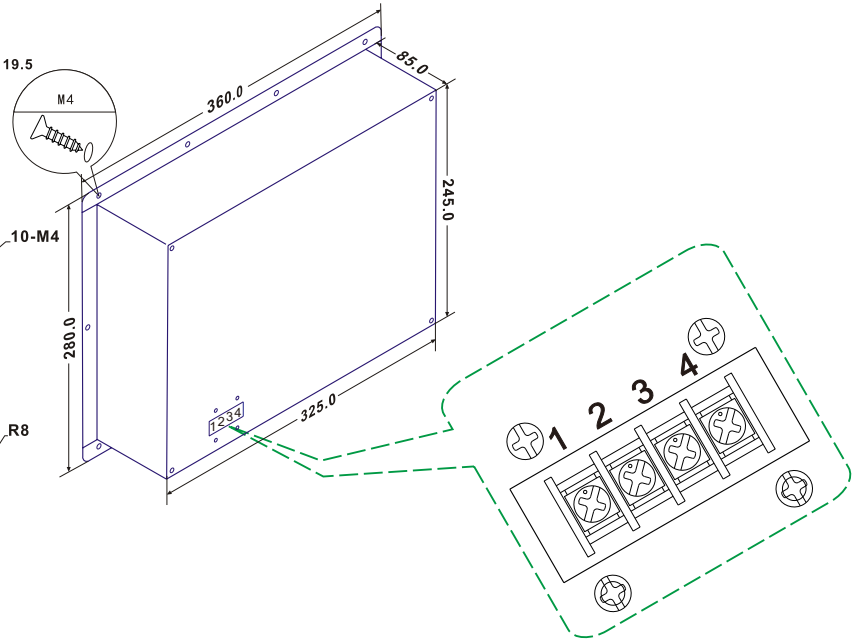

Application	2 inputs, 2 audio parallel outputs, DSP stereo module. Applied to 2.1 system or three-way speaker.		
Control	by encoder or by software. 1-A, 2-B, 3-C channels are available, 4-D channel is unused.		
Diagram	<p> </p>		
Model	M45.9	M60.12	M80.12
8Ω output power	2X450W+900W	2X600W+1200W	2X800W+1200W
4Ω output power	2X720W+1440W	2X960W+1920W	2X1280W+1920W

Connector	Input: XLR Output: SPEAKON or KF25C-7.62 barrier terminal		
Input sensitivity: 1.8V; Input impedance: 20KΩbalanced; Damping factor: > 400 @ 8Ω; Hum&noise: -95dB ; THD: < 0.1% (20Hz - 20KHz, 1W) Frequency response: 20Hz - 20KHz (±0.3dB) @ 1W, 8Ω ; cooling: temperature controlled ; Protection: short circuit, open circuit, direct voltage, overheat, overvoltage, radio-frequency, ultralow frequency; power requirement: AC 180V-240V or AC90V-120V, 50-60Hz ; Module size: 360mm X 280mm X 88mm; Packing size: 415mm X 300mm X 160mm			
Net weight	6.4KG		
Gross weight	7.5KG		



Each channel is equipped with a balanced 3-pin input connector. It requires to use a standard cable and can be switched fast. Balanced input connections are recommended so as to reduce AC hum and interruption, especially when using long cable. Unbalanced connection should be used in circumstance when with short cable, and the signal resistance should be no more than 600 ohms.

XLR INPUT

1. Balanced input connection

- a. The XLR input connectors are electronically balanced;
- b. XLR input connectors should be wired as follows:

Pin 1 Ground/shield

Pin 2 Hot (+)

Pin 3 Cold (-)

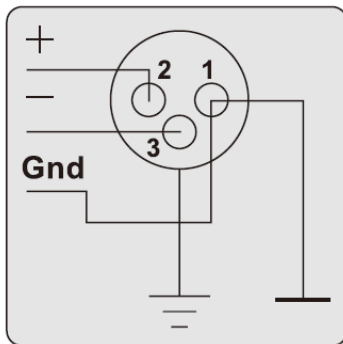

2. Unbalanced input connection

To connect an input to an unbalanced source, it is possible to connect pins 1 and 3 in the XLR plug at the amplifier end of the cable. However, a better method is to connect pin 3 to the shield at the source end of the cable, as this usually results in better hum and noise rejection. Balanced input connections are recommended whenever possible.

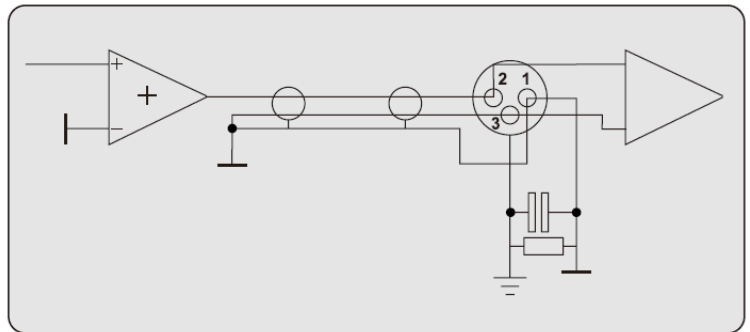

- No bridge mode; Cannot work under 4 ohms load.
- Do not support hot-plugging. Make sure the power is off before attempting to Make any input or output connections.

SPEAKON OUTPUT

Each channel accepts normal 2-wire cable.

- Stereo or parallel mode- connects each speaker to amplifier channel accordingly.
- Mode can be chosen by pressing its button at the rear panel.
- Please refer to the photo for the connections.

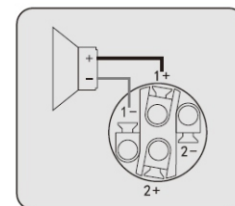

OUTPUT TERMINAL SAFETY WARNING! Do not touch output terminals while amplifier power is on. Make all connections with amplifier turned off. Risk of hazardous energy!

Digital Sound Control

Power-On

During power-on the display shows for a brief moment the welcome message.

```
DSC2.2STD
Sound Controller
```

After power-on the system starts with the last stored or last loaded preset. If no preset is available the system starts with default settings. Identical with first power-on and with **Factory Default** in the **Reset** menu.

User Interface actions

Push Button

- short press** selects the menu item indicated by a triangle (▶) or confirms the settings
- long press** sends back to the upper menu level or cancel modifications and restores the old settings

Rotary Function Dial scrolls the menu and modifies the settings

System behaviour

Important: Any modifications of the settings will be not automatically stored !

Modified settings can be stored in the **Presets** menu. Leaving the menu without storing, the system requests a confirmation: 'yes or no'.

```
Store Settings?
>yes<
```

The indicator LED

The LEDs can be used optionally and fulfil 3 functions:

Channel Mute (slow blinking)

If the Channel is muted the corresponding LED is blinking slow.

Clip & Limiting

This indication is a sum of 3 functions

- Input clip the Input reaches the 0dBFS (+15dBu)
- Output clip the Output reaches the 0dBFS (+15dBu)
- Limiter active the Limiter reaches the threshold level

EEPROM Error (fast blinking)

If the EEPROM content is corrupt, during power on, the system displays in the LCD an error message which informs the user about the appropriate action and waits for a confirmation to proceed (**short press** the **Push Button**).

Digital Sound Control

Menu Overview

A flat and easy to handle menu structure enables the user to setup the system in a quick and uncomplicated way. Each menu item can be called by a **short press** of the **Push Button**, or left by a **long press**. The use of 'EXIT' is also available.

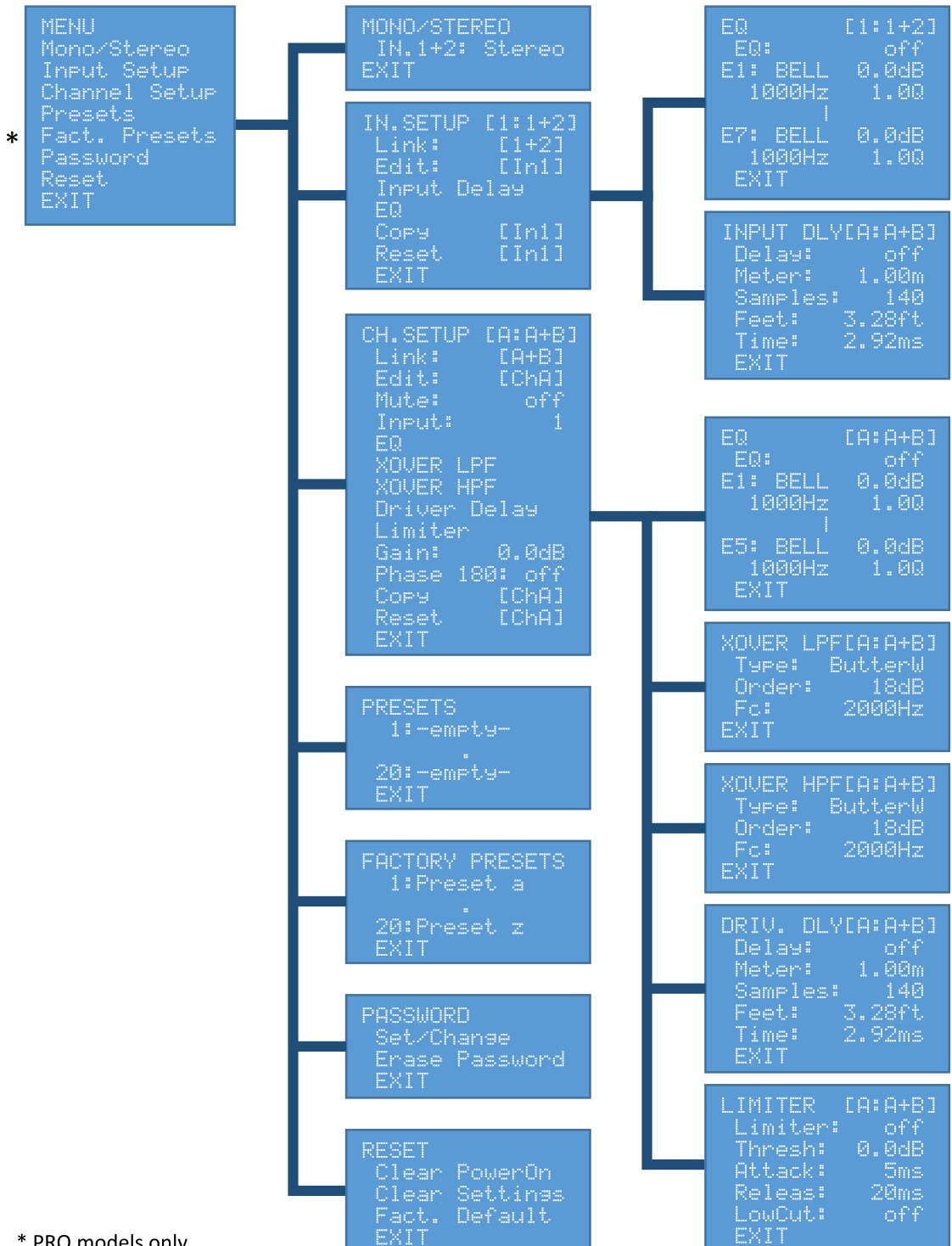

* PRO models only

Digital Sound Control

Root Menu

The **Root** menu is accessible for everyone and gives information about the signals, loaded preset, password, device ID & name (Network), model and the system info. The **Rotary Function Dial** is used for cycling through the different screens.

Level Screen

The Input level is indicated by a bar graph with a peak hold function. The resolution is from -70dB up to +15dB within 28 steps. The peak hold is set to 1 sec.



Limiter

If the limiter is switched on, the left side of the display still shows the Input level, as described above. The right side indicates the limiter reduction level, in case the signal exceeds the threshold level. The peak hold function is switched off.



No Signal

Below -70dB the display shows the corresponding text. The left hand side character shows the related Channel.



Digital Volume (Optional feature by Hardware-Jumper)

While changing the volume the level is displayed in the corresponding Channel row. Eg. Channel A is routed to Input 1 the 'Volume 1' is displayed in the 'A:' row.



If volume is off, the display shows permanently an 'off'. Eg. 'A:Volume 1 off'.



PRESET Screen

After first power-on or when **Factory default** of the **Reset** menu was executed, the display shows 'Default Settings' below 'PRESET'.



If the 'Default Settings' were modified but not stored, a '(modified)' is displayed next to 'PRESET'.



Note: If the 'modified' settings will be not stored to a preset, the 'Default Settings' will be loaded at next power-on. In such case the previous modifications are lost.

Digital Sound Control

Root Menu

PRESET Screen (continued)

Once the settings are stored to a preset, as example: '1: 2Ch X-Over' the number and name are displayed below PRESET (Preset #1, preset name: 2Ch X-Over).

```
PRESET
1: 2Ch X-Over
```

If settings of loaded presets were modified but not stored, a '(modified)' is displayed next to PRESET.

```
PRESET(modified)
1: 2Ch X-Over
```

Note: If the modified preset will not be stored, the original (unmodified) preset will be loaded at next power-on. In such case the previous preset modification is lost.

If a preset was loaded or stored, the preset number and preset name is displayed.

```
PRESET
1: 2Ch X-Over
```

A small 'f' indicates if a factory preset was loaded. (see page 20 'Factory Presets Menu')

```
PRESET
f 1: 2Ch X-Over
```

PASSWORD Screen

The Password menu offers the option to set a password to avoid unauthorised tampering on stored settings. The display shows one of two possible messages as shown at right.

```
PASSWORD
No Password Set
```

```
PASSWORD
System Protected
```

DEVICE ID & NAME Screen

Shows the assigned ID number and name in a network. The default settings on delivery are: ID 0, -no name-.

Note: The ID number and name can only be assigned and changed by the PC remote control software RC1.

Numbers can range from 0 to 255.

Names can consist a maximum of 16 characters.

```
DEVICE ID: 0
-no name-
```

```
DEVICE ID: 255
AbCdEfGhIjKlMnOp
```

MODEL Screen

Shows the DSC model number.



SYSTEM INFO Screen

Shows the current system software version (Firmware).

```
SYSTEM INFO
250116-1050
```

Digital Sound Control

Main Menu

From each position in the **Root** menu the **Main** menu can be called by **short press** the **Push Button**.

If a password protection is active the user must prompt the password to enter the **Main** menu.

Password

Use the **Rotary Function Dial** to change the number between 0 to 9 and confirm each number by **short press** the **Push Button**. After entering the correct 4 digit Code the **Main** menu will be entered. Any number between 0000 and 9999 can be selected.

```
ENTER PASSWORD:
0000
```

Main Menu

The **Main** menu leads to following submenus:

- Mono/Stereo
- Input Setup
- Channel Setup
- Presets
- Factory Presets *
- Password
- Reset

```
MENU
Mono/Stereo
Input Setup
Channel Setup
Presets
Fact. Presets
Password
Reset
EXIT
```

*Factory Presets

The **Fact. Presets** menu is optional and only available on the PRO models. This menu can contain system dependent presets provided by the manufacturer. Factory presets can only be loaded by end users. They can be modified and stored in the **Presets** menu.

USB - PC Remote Control

If a PC takes control of the settings, eg. by RC1 control software, the main menu access via Rotary Function Dial and Push Button is denied. The display shows for a brief moment 'Remote Control On'. If the PC stops control of the settings, the display shows 'Remote Control Off'.

```
Remote Control
On
```

```
Remote Control
Off
```

Digital Sound Control

Mono/Stereo Menu

Two Inputs can be summed to a mono signal. The level of each Input is reduced by 6dB, so that the resulting signal is again 0dB.



IN. 1+2:

Prior the digital volume stages (selectable by hardware jumper) both Inputs are added and the sum is reduced by 6dB. This mono signal is passed then to both corresponding Input delay and EQ stages.

Pressing the **Push Button** toggles between mono and stereo. The result is immediate audible.

DSC4.4PRO:

In case of 4 Inputs the same function is available for input 3 and Input 4.

Digital Sound Control

Input Setup Menu

In the **Input Setup** menu and its submenus all functions can be set and modified while the system is running.

This enables the user the possibility to listen immediately to any changes until the utmost result is achieved.

```
IN.SETUP [1:1+2]
Link:    [1+2]
Edit:    [In1]
Input Delay
EQ
Copy     [In1]
Reset    [In1]
EXIT
```

<u>Link:</u>	<u>Edit:</u>	<u>Copy</u>	<u>Reset</u>
[---]	[In1]	to [1-2]	yes
[1+2]	[In2]	to [3-4]	no
[3+4]	[In3]	to [1-4]	
[1-4]	[In4]		

Input 3 and 4 are only available on DSC4.4PRO

[1:1+2]

In order to achieve a minimum of effort during setting modifications, Input settings can be synchronized by using the '**Link**' function.

The upper case header line of the **Input Setup** menu and each submenu shows the status of **Link** and **Edit**.

Above example indicates that Input 1 is selected for settings editing '**Edit: [In1]**'.

The Link function is set to Input 1 and Input 2 '**Link: [1+2]**'.

As result:

All setting modifications made on Input 1 are real time synchronized with Input 2.

Link:

Pressing the **Push Button** rotates the '**Link**' between [1+2] and [---] (not linked).

If Inputs are linked, all subsequent settings will be applied to each Input.

DSC4.4PRO: In case of 4 inputs [1+2], [3+4], [1-4], [---] can be selected.

Digital Sound Control

Input Setup Menu

Edit:

If Inputs are not linked [---], setting modifications are only effective at the selected Input [In1] or [In2].

If Inputs are linked [1+2], the actual settings of the selected Input are displayed, but setting modifications will take effect at each linked Input.

Be carefully in case if Inputs are linked, because the display shows settings of the selected Input only, but the settings of the non-selected Inputs might be different. In such case an empty arrow is displayed (▶), instead of (▶).

DSC4.4PRO: In case of 4 Inputs [In1], [In2], [In3], [In4] can be selected.

Copy

The settings of the current Input selection, eg. [In1] can be copied to Input 2.

The 'Copy' is initiated by a short press of the **Push Button**.

Next, select '[1-2]' or 'EXIT' with the **Rotary Function Dial**.

DSC4.4PRO: In case of 4 Inputs [1-2], [3-4], [1-4], [Exit] can be selected.

Reset

The settings of the current Input selection, eg. [In1] can be reset to their default values. The 'Reset' is initiated by a short press of the **Push Button**.

Next, select 'yes' or 'EXIT' with the **Rotary Function Dial**.

Digital Sound Control

Input Delay Menu

The Input Delay is intended for long loudspeaker run time compensations. Depending from the model, the range is up to 900ms per Input. 4 selectable units allow precise and flexible adjustments of the distances in meter, feet, time and number of samples @ 48kHz (1 sample = 20.83us or 7.146mm).

```
INPUT DLY[1:1+2]
Delay:          off
Meter:          1.00m
Samples:        140
Feet:           3.28ft
Time:           2.92ms
EXIT
```

Delay:

Switches the Input delay on and off. This action is executed immediately and is immediate audible.

```
Meter: [m], Samples:,
Feet: [ft] and Time: [ms]
```

All units can be incremented and decremented by 1 over the whole range.

Digital Sound Control

Input EQ Menu

The Input EQ offers 7 identical filter stages named: E1 – E7. The whole filter unit can be bypassed to compare a flat frequency response vs the filtered signal.

The screenshot shows the Input EQ menu with the following text:

```
EQ [1:1+2]
EQ: off
E1: Bell 0.0dB
    60Hz 1.00
|
E7: Bell 0.0dB
    14000Hz 1.00
EXIT
```

Below the menu, there are four boxes representing filter settings:

- EQ**: off
- Filter Type**: off, Bell, High Shelf 6/12dB, Low Shelf 6/12dB, Notch
- Gain**: -15dB to +15dB
- Fc**: 20 Hz to 20 kHz
- Q**: 0.5 to 20

EQ:

With 'EQ: off' all 7 filter stages are bypassed and the signal response is flat. This action takes immediately place, so that the differences are immediately audible.

En:

Each of the 7 EQ filter stages are default off. The settings will be displayed and accessible for adjustments if one of 6 available filter types has been selected.

The **Rotary Function Dial** navigates between the settings.

The current position is indicated by a triangle (▶).

Pressing the **Push Button** enables the adjustment of the settings by using the **Rotary Function Dial**. A **short press** of the **Push Button** takes over settings, while a **long press** cancels the adjustment and returns without modifications.

Modifications of Fc, Gain and Q are immediately audible. The new selected filter type will be audible after confirmation (**short press** of the **Push Button**).

Digital Sound Control

Input EQ Menu

Filter Type

Each EQ filter stage can be switched off or selected as:

Bell, Low Shelve 6 -, Low Shelve 12dB, High Shelve 6 -, High Shelve 12dB or Notch.

The quality Q is available for Bell and Notch only.

Gain for Bell, High and Low Shelve

The values ranges from -15dB to +15dB.

Settings resolution: 0 to +/-10dB in 0.5dB steps and above in 1.0dB steps.

Gain for Notch

The individual damping for Notch is selectable from -3 to -18dB in 3dB steps and above from -20 to -60dB in 20dB steps. Maximum is infinite damping indicated by a 'oodB' in the display.

Center / Corner Frequency (Fc)

The values ranges from 20Hz to 20kHz and can be adjusted with a precision of 1 Hz over the full frequency range.

The frequency modification starts always first with the leftmost digit and follows the leftmost position automatically.

This allows a very fast adjustment over the full frequency range.

Each press of the **Push Button** moves the decimal place toward the first digit.

A cursor indicates the position of the decimal place.

Quality Q for Bell

The values ranges from 0.5 to 20.

Settings resolution: 0.5 to 1.0 in 0.1, 1.0 to 10 in 0.5, 10 to 20 in 5.0 steps.

Quality Q for Notch

The values ranges from 1 to 30.

Settings resolution: 1 to 10 in 1.0 steps and from 10 to 30 in 5.0 steps.

Digital Sound Control

Channel Setup Menu

In the Channel **Setup** menu and its submenus all functions can be set and modified while the system is running.

This enables the user the possibility to listen immediately to any changes until the utmost result is achieved.

<pre> CH.SETUP [A:A+B] Link: [A+B] Edit: [ChA] Mute: off Input: 1 EQ XOVER LPF XOVER HPF Driver Delay Limiter Gain: 0.0dB Phase 180: off Copy [ChA] Reset [ChA] EXIT </pre>	<u>Link:</u> [---] [A+B] [C+D] [A-D]	<u>Edit:</u> [ChA] [ChB] [ChC] [ChD]	<u>Copy</u> to [A-B] to [C-D] to [A-D]	<u>Reset</u> yes no
--	--	--	---	---------------------------

Channel C and D are only available on DSC2.4 and DSC4.4

<u>Input:</u> 1 2 3 4	<u>Mute:</u> off on	<u>Gain:</u> -15 dB to +15 dB	<u>Phase 180:</u> off on
-----------------------------------	---------------------------	--	--------------------------------

Input 3 and 4 are only available on DSC4.4PRO

[A:A+B]

In order to achieve a minimum of effort during setting modifications, Channel settings can be synchronized by using the 'Link' function.

The upper case header line of the **Channel Setup** menu and each submenu shows the status of 'Link' and 'Edit'.

Above example indicates that Channel A is selected for settings editing 'Edit: [ChA]'. The Link function is set to Channel A and Channel B 'Link: [A+B]'.

As result:

All setting modifications made on Channel A are real time synchronized with Ch. B.

Link :

Pressing the **Push Button** toggles the 'Link' between [A+B] and [---] (not linked). If Channels are linked, all subsequent settings will be applied to each Channel.

DSC2.4PRO and DSC4.4PRO:

In case of 4 Channels [A+B], [C+D], [A-D] and [---] can be selected.

Digital Sound Control

Channel Setup Menu

Edit:

If Channels are not linked [---], setting modifications are only effective at the selected Channel [ChA] or [ChB].

If Channels are linked [A+B], the actual settings of the selected Channel are displayed, but setting modifications will take effect at each linked Channel.

Be carefully in case if Channels are linked, because the display shows settings of the selected Channel only, but the settings of the non-selected Channel might be different. In such case an empty arrow is displayed (▶), instead of (▶).

DSC2.4PRO and DSC4.4PRO:

In case of 4 Channels [ChA], [ChB], [ChC], [ChD] can be selected.

Mute:

'on' mutes the output while 'off' switches the output on.
Press the **Push Button** to toggle between 'on' and 'off'.

Input:

Selects the Input source for the current Channel.

Gain:

The 'Gain' has a total control of 30dB and ranges from -15dB to +15dB.
Settings resolution: 0 to +/-10dB in 0.5dB steps, +/-10 to 15dB in 1.0dB steps.

Phase 180:

The signal of each Channel can be turned exactly by 180 degree by selecting 'on'.

Copy

The settings of the current Channel selection, eg. [ChA] can be copied to Channel B.
The 'Copy' is initiated by a short press of the **Push Button**.
Next, select '[A-B]' or 'Exit' with the **Rotary Function Dial**.

DSC2.4PRO and DSC4.4PRO:

In case of 4 Channels [A-B], [C-D], [A-D] and [Exit] can be selected.

Reset

The settings of the current Channel selection, eg. [ChA] can be reset to their default settings. The 'Reset' is initiated by a short press of the **Push Button**.
Next, select 'yes' or 'EXIT' with the **Rotary Function Dial**.

Digital Sound Control

Channel EQ Menu

The Channel EQ offers 5 identical filter stages named: E1 – E5. The whole filter unit can be bypassed to compare a flat frequency response vs the filtered signal.

<pre>EQ [A:A+B] EQ: off E1: Bell 0.0dB 1000Hz 1.00 E5: Bell 0.0dB 1000Hz 1.00 EXIT</pre>	<pre>EQ: off on</pre>	<pre>Filter Type: off Bell High Shelve 6/12 dB Low Shelve 6/12 dB Notch</pre>	<pre>Gain: -15 dB to +15 dB</pre>	<pre>Fc: 20 Hz to 20 kHz</pre>	<pre>Q: 0.5 to 20</pre>
--	-----------------------	---	-----------------------------------	--------------------------------	-------------------------

EQ:

With 'EQ: off' all 5 filter stages are bypassed and the signal response is flat. This action takes immediately place, so that the differences are immediately audible.

En:

Each of the 5 EQ filter stages are default off. The settings will be displayed and accessible for adjustments if one of 6 available filter types has been selected.

The **Rotary Function Dial** navigates between the settings.

The current position is indicated by a triangle (▶).

Pressing the **Push Button** enables the adjustment of the settings by using the **Rotary Function Dial**. A **short press** of the **Push Button** takes over settings, while a **long press** cancels the adjustment and returns without modifications.

Modifications of Fc, Gain and Q are immediately audible. The new selected filter type will be audible after confirmation (**short press** of the **Push Button**).

Digital Sound Control

Channel EQ Menu

Filter Type

Each EQ filter stage can be switched off or selected as:

Bell, Low Shelf 6 -, Low Shelf 12dB, High Shelf 6 -, High Shelf 12dB or Notch.

The quality Q is available for Bell and Notch only.

Gain for Bell, High and Low Shelf

The values ranges from -15dB to +15dB.

Settings resolution: 0 to +/-10dB in 0.5dB steps, +/-10 to 15dB in 1.0dB steps.

Gain for Notch

The individual damping for Notch is selectable from -3 to -18dB in 3dB steps and above from -20 to -60dB in 20dB steps. Maximum is infinite damping indicated by a 'oodB' in the display.

Center / Corner Frequency (Fc)

The values ranges from 20Hz to 20kHz and can be adjusted with a precision of 1 Hz over the full frequency range.

The frequency modification starts always first with the leftmost digit and follows the leftmost position automatically.

This allows a very fast adjustment over the full frequency range.

Each press of the **Push Button** moves the decimal place toward the first digit.

A cursor indicates the position of the decimal place.

Quality Q for Bell

The values ranges from 0.5 to 20.

Settings resolution: 0.5 to 1.0 in 0.1, 1.0 to 10 in 0.5, 10 to 20 in 5.0 steps.

Quality Q for Notch

The values ranges from 1 to 30.

Settings resolution: 1 to 10 in 1.0 steps, 10 to 30 in 5.0 steps.

Digital Sound Control

XOVER Menus

Each Channel has a low pass filter (LPF) and a high pass filter (HPF) which allows completely independent settings. Low and high pass filter can run at the same time and are used together as a band pass filter.

XOVER LPF (Low Pass Filter)

<pre>XOVER LPF[A:A+B] Type: ButterW Order: 18dB Fc: 20000Hz EXIT</pre>	<p><u>Filter Type:</u> off Butterworth Linkwitz</p>	<p><u>Order:</u> 6 dB to 24 dB</p>	<p><u>Fc:</u> 20 Hz to 20 kHz</p>
---	---	--	---

XOVER HPF (High Pass Filter)

<pre>XOVER HPF[A:A+B] Type: ButterW Order: 18dB Fc: 20Hz EXIT</pre>	<p><u>Filter Type:</u> off Butterworth Linkwitz</p>	<p><u>Order:</u> 6 dB to 24 dB</p>	<p><u>Fc:</u> 20 Hz to 20 kHz</p>
--	---	--	---

Type:

Both filters can be switched off or independent used as Butterworth or Linkwitz.

Order:

If Butterworth is selected the order is selectable from 6 to 24dB in 6dB steps. For Linkwitz 12dB and 24dB are available.

Fc:

The corner frequency values ranges from 20Hz to 20kHz and can be adjusted with a precision of 1 Hz over the full frequency range.

The frequency modification starts always first with the leftmost digit and follows the leftmost position automatically.

This allows a very fast adjustment over the full frequency range.

Each press of the **Push Button** moves the decimal place toward the first digit.

A cursor indicates the position of the decimal place.

Digital Sound Control

Limiter Menu

The full range peak limiter is placed at the end of the systems signal path. This prevents effectively unwanted clipping of the outputs of all Channels.

```
LIMITER [A:A+B]
Limiter:  off
Thresh:  0.0dB
Attack:   5ms
Releas:  20ms
LowCut:   off
EXIT
```

The impact of modifications of the limiter settings can be monitored by the bar graph, showed in the 1st line of the display.

```
A: [|||||] | [|||||]
Thresh: >0.0dB<
```

Limiter:

Use the **Push Button** to switch the limiter on and off.

Attack:

The attack time is adjustable from 1ms up to 250ms.
Settings resolution: 1-20 ms in 1ms, 20-100ms in 5ms, 100-250ms in 10ms steps.

Release:

The release time is adjustable from 5ms up to 3000ms.
Settings resolution: 5-100 in 5ms, 100-500 in 50ms, 500-3000ms in 100ms steps.

Threshold:

The threshold has a total control of 42dB and ranges from -27 up to +15dB.
Settings resolution: 0 to +/-10dB in 0.5dB steps, outside in 1dB steps.

LowCut:

The use of a limiter for full range applications requires sometimes to keep the low frequencies away from the peak detection circuit. **LowCut** indicates the corner frequency of an adjustable high pass filter with 12dB/oct. It can be switched off or adjusted from 60 to 1000Hz. Settings resolution:
60-100Hz in 5Hz steps, 100-300Hz in 10Hz steps, 300-1000Hz in 25Hz steps.

Digital Sound Control

Driver Delay Menu

The **Driver Delay** improve accuracy of multiple loudspeaker systems (Time-Align). 4 selectable units allow precise and flexible adjustments of the distances in meter, feet, time and number of samples @ 48kHz (1 sample = 20.83us or 7.146 mm).

```
DRIV. DLY[A:A+B]
Delay:      off
Meter:     1.00m
Samples:   140
Feet:     3.28ft
Time:     2.92ms
EXIT
```

Delay:

Switches the driver delay on and off. This action is executed immediately and immediate audible.

```
Meter: [m], Samples:,
Feet: [ft] and Time: [ms]
```

These units change their values based on increments/decrements of samples @ 48kHz, because it is the smallest and most precise unit for short delays. The range is adjustable from 1 - 480 samples, 0.007 - 3.43m, 0.02 - 11.3ft, 0.02 - 10ms.

Digital Sound Control

Preset Menu

Up to 20 user presets can be stored. Select with the **Rotary Function Dial** the desired preset number and press the **Push Button**.

Only the 'Store' and 'EXIT' options are available in case the location is '-empty-', otherwise also 'Load' and 'Clear' are available for selection.

```
PRESETS
 1:-empty-
      .
20:-empty-
EXIT
```

```
OPTIONS
Store
Load
Clear
EXIT
```

Store

The display informs the user for a brief moment to enter a name, followed by the edit screen.

```
Please Enter
 a Name
```

```
>_ <
EXIT Clr Store
```

Enter the name in the following display. The name can have up to 11 characters. Select the characters by using the **Rotary Function Dial**. The cursor position is shown by an underscore. Move to the next position with the **Push Button**. If the last position is reached the cursor will move to the first position again.

Long press the **Push Button** leave the name edit field and reach the option 'Store'. Select the other options 'Clear' and 'EXIT' with the **Rotary Function Dial**.

Pressing the **Push Button** confirms the selection. Selecting 'store' will not prompt for a confirmation. A brief message is displayed.

```
Preset
Stored
```

Long press the **Push Button** exits the name edit mode without preset storing.

Further rotating of the **Rotary Function Dial** shifts a bold cursor to the name field again. Pressing the **Push Button** at each position to edit the name again.

Load

The preset is loaded without further confirmation.

Note: The Preset will become immediate audible !

Clr (Clear)

Deletes the selected preset. This process requires a 'yes' or 'Exit' confirmation. It can be cancelled by selecting 'EXIT' with the **Rotary Function Dial** or by **long press** the **Push Button**.

Digital Sound Control

Factory Presets Menu (PRO models only)

Up to 20 pre-programmed factory presets can be stored by the manufacturer. Select with the **Rotary Function Dial** the desired preset number and press the **Push Button**.

Factory presets can only be loaded by end users. If desired, modified factory presets can be stored in the **Presets** menu. The preset names are given individually by the manufacturer.

```
FACTORY PRESETS
1: preset a
.
20: preset z
EXIT
```

```
OPTIONS
Load
EXIT
```

Load

The preset is loaded without further confirmation.

Note: The Preset will become immediate audible !

Digital Sound Control

Password Menu

The system provides a 4 digit password protection to avoid unauthorized or unintended modifications of the settings.

All combinations from 0000 to 9999 can be used as password.

```
PASSWORD
Set/Change
Erase
EXIT
```

Navigating from the Root menu to Main menu with Password

Once the password is set, only the **Root** menu is accessible. When branching to the **Main** menu, the system is requesting the password.

Use the **Rotary Function Dial** to select numbers [0-9] for each of the 4 digits.

Press short the **Push Button** to move to the next digit.

```
ENTER PASSWORD
0000
```

The entry can be terminated any time by **long press** the **Push Button**.

```
PASSWORD
ACCEPTED
```

For a brief moment the display indicates if the correct or wrong password has been entered.

```
WRONG
PASSWORD
```

Set/Change

If no password is set the screen requests to enter a new code.

```
ENTER NEW CODE
0000
```

If a password is set the system requests a confirmation of the old code, before entering the new code.

```
ENTER OLD CODE
0000
```

Erase

This menu item is available if previously a password has been allocated.

```
ENTER OLD CODE
0000
```

A confirmation of the existing code is requested before a new password can be set.

```
ENTER NEW CODE
0000
```

A few brief displays guides the password entry.

Digital Sound Control

Reset Menu

```
RESET
Clear PowerOn
Clear Settings
Fact. Default
EXIT
```

Clear PowerOn

Removes the selected preset and loads the default settings. This action takes place after confirmation.

The PRESET screen in the **Root** menu displays:

‘Default Settings’.

At next power-on, the default settings are loaded.

```
PRESET
Default Settings
```

Clear Settings

All Input and Channel settings are reset to their default settings. If a preset was loaded, the ‘(modified)’ in the **PRESET** screen of the **Root** menu indicates this action.

This action is not stored to the selected preset.

Without storing, the originally last selected preset will be loaded at next power-on.

```
PRESET(modified)
1: 2Ch X-Over
```

Fact. Default (Factory Default)

After confirmation, all stored presets and the password are deleted.

All settings are reset to their default settings.

Existing factory presets are left untouched if a ‘Factory Default’ will be executed.

Note:

If the system is password protected, the Factory Default, Clear PowerOn and Clear Settings can’t be executed without valid code entry.

Digital Sound Control

Default Settings

At first power-on, all Input and Channel settings are set to their default values. These settings correspond to a flat signal response between Input and output.

Listing of functions and their default settings

1. Mono: off
2. Input Delay: off, set to 0 meter
3. Input EQ: E1-E7 off, set to Bell, gain: 0dB, Q: 1.0
4. Input 1 routed to Channel A, DSC2.4: Channel A and Channel C
5. Input 2 routed to Channel B, DSC2.4: Channel B and Channel D
6. Input 3 routed to Channel C (DSC4.4 only)
7. Input 4 routed to Channel D (DSC4.4 only)
8. Mute: off
9. Channel Gain: 0dB
10. Channel Phase 180: off
11. Xover HPF: off, set to Butterworth 18dB/oct.
12. Xover LPF: off, set to Butterworth 18dB/oct.
13. Channel EQ: off, E1-E5 off, set to Bell, gain: 0dB, Q: 1.0
14. Limiter: off, Treshold: 0dB, Attack: 5ms, Release: 20ms, LowCut: off
15. Driver Delay: off, set to 0 meter
16. Input Link: off
17. Channel Link: off
18. Xover Link: off
19. Presets: 1-20 empty
20. Factory Presets: 1-20 empty, manufacturer dependent (PRO models only)
21. Device ID: 0, -no name-
22. Digital Volume control: on, hardware jumper JP2 dependent